

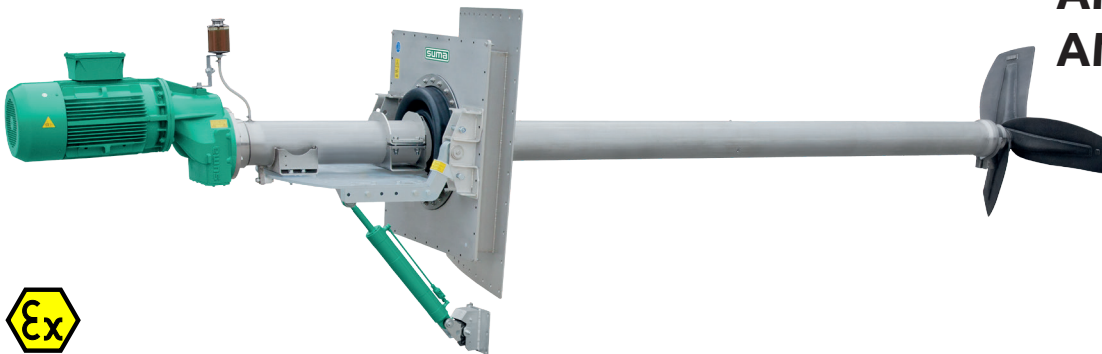

Long-axis agitator Giantmix

AMT3 110-135

AMT5 185-135



Powerful
High efficiency
Innovative design

Application

Dry matter content up to 14 %
Substrate temperature up to 70°C
pH-value 6.5 - 8.5

Technical data

Tube length 4.0 / 5.0 m
Tube Ø 220 x 8 mm in ss316
15° sealing plate 143 x 143 cm in ss304
ss316 version on request
Sound pressure level 75 dB(A)
Installation up to 6 m below substrate level
Damping system with special rubber on cylinder wall
bracket and in hinged brackets
Oil inspection glass for monitoring the tightness
Agitator completely manufactured in modular design

Motor

Performance: 11 / 18,5 kW : 8 poles
400 V, 50 Hz, 725 rpm, special tensions on request
PTC thermistors 160°C as overheat protection
Ex-Motor II 3G Ex nA IIA T3 Gc (ex-zone 2)

Gear

Spur gear drive, helical teeth, low noise level
Reduction ration $i = 5.37$
Oil chamber, gear oil SAE 85W-140 / API GL-5
Oil change after 2,000 operating hours

Bearing

Bearing housing with oil chamber
2 tapered roller bearings to absorb the axial forces
Mechanical seal SiC/SiC, independent of rotation
direction
Interim bearings for the drive shaft

Propeller

3-blade high efficiency propeller, dynamically balanced

AMT3	11,0 kW	propeller HD 1050	135 rpm
AMT5	18,5 kW	propeller HD 1200	135 rpm

Standard in hardened steel, optional ss304

Adjustment range

Horizontal through pivoting frame $\pm 20^\circ$
Sealing plate 15° optional right/left preset
Vertical through hydraulic cylinder $\pm 30^\circ$
Tank opening: 1,000 x 1,000 mm (Plate 143 cm)

Ex-zone

Ex-Zone 2 (outside tank) and Zone 1 (inside tank)
Classification mechanical components:
 II 2G ck IIA T3

Control box (optional)

Soft start or frequency converter
Delivery with 4.0 m connecting cable

Long-axis agitator Giantmix

AMT3 110-135

AMT5 185-135

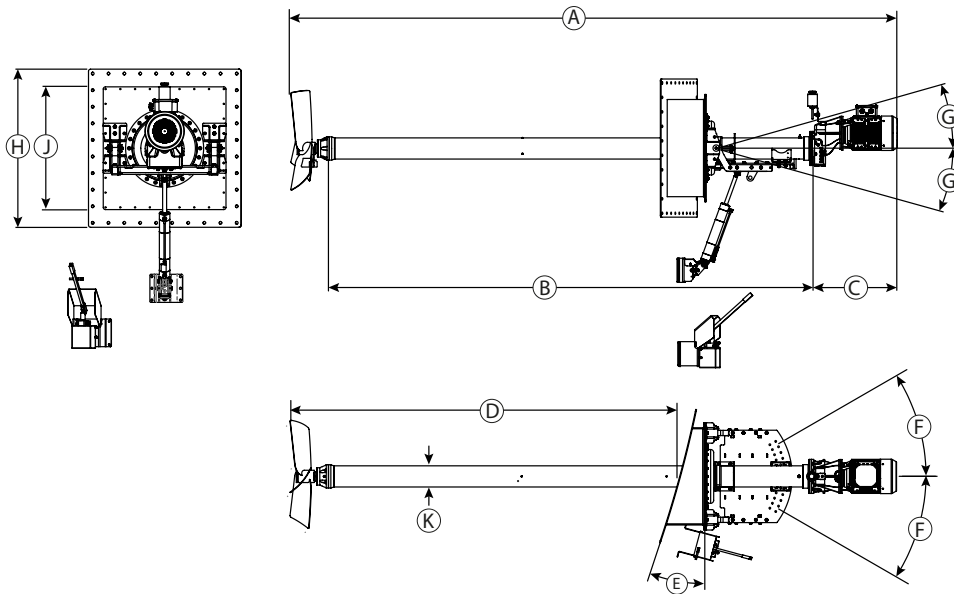

Dimensions

Type	A [mm]	B [mm]	C [mm]	D [mm]	E	F	G	H [mm]	J [mm]	K [mm]
AMT3/5	5,265 / 6,265	4,000 / 5,000	900	2,970 / 3,970	15°	20°	30°	1,430 x 1,430	990 x 990	220

Technical data

Type	Rated power [kW]	Rated Voltage [VΔ]	Rated current [AΔ]	Frequency [Hz]	Power factor cos φ	Gear reduction ratio	Propeller speed [rpm]	Propeller diameter [mm]	Axial force [kN]	Flow velocity [m/s] *	Pumping rate Water [m³/min]	Weight approximate [kg]
AMT3	11.0	400	26.5	50	0.70	5.37	135	1,050	4.0	1.9	90	1,300
AMT5	18.5	400	38.0	50	0.79	5.37	135	1,200	4.4	2.0	135	1,300

Subject to technical changes

* measured in water and 1.2 m distance